

Numatic International Spare Parts

Model No: RSV-200 / RSV-200M

231712
DRAWING: EXP-0329 ISS:A13
12/06/2008

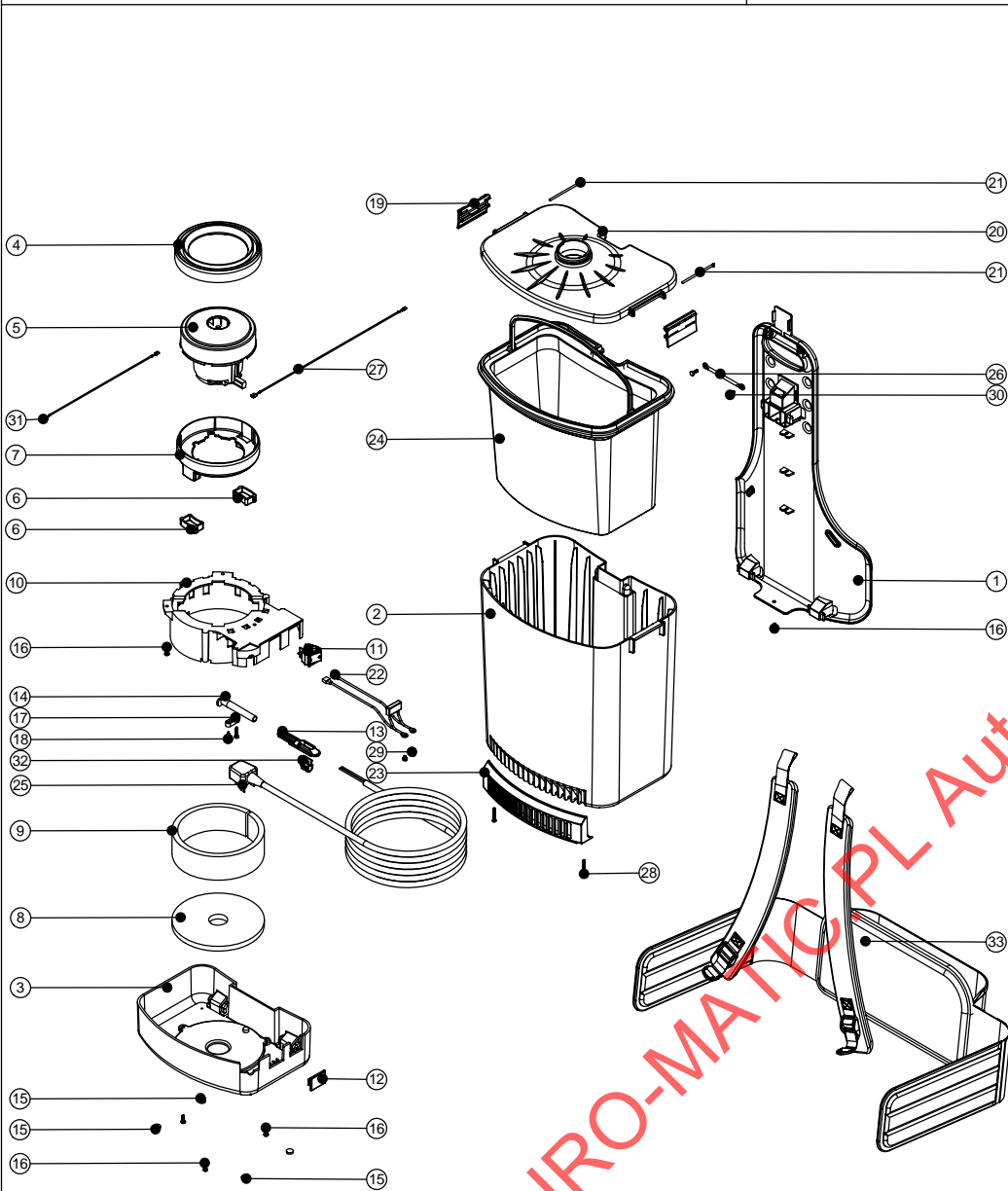

Numatic International Spare Parts

Model No: RSV-200 / RSV-200M

POS:	ITEM NO:	DESCRIPTION:	COMMENTS:
1	206509	BACK SUPPORT MOULDING (LONG)	
2	328057	GREY BODY MOULDING (PRINTED BLACK NUMATIC LOGO)	
3	227184	BASE MOULDING	
4	202065	BOTTOM MOTOR GASKET	
5	205493	230V 1 STAGE THRO FLOW CUP MOTOR (DL11103T) TCO (MARKED 230V)	
	205413	120V 1 STAGE THRO FLOW CUP MOTOR (DL11101) TCO	
6	227885	MOUNTING RUBBER	
7	229514	MOTOR SPACER (CUP MOTOR)	
8	203016	TOP FELT	
9	203017	SIDE FELT	
10	325025	BLACK MOTOR HOUSING MOULDING	
11	220552	RED ROCKER SWITCH	
12	206431	BLANKING PLATE	
13	227636	STRAIN RELIEF	
14	220923	STRESS RELIEF	
15	206322	RUBBER FOOT BLACK	
16	219101	No8 X 1/2 INCH LONG POZI PAN PLASTITE SCREW	
17	227008	BLACK CABLE CLAMP	
18	219107	No6 X 5/8 INCH LONG POZI PAN PLASTITE SCREW	
19	227186	TOGGLE MOULDING	
20	227183	LID MOULDING	
21	206326	TOGGLE PIN	
22	220142	SUPPRESSOR ASSEMBLY	
23	227199	DIFFUSER MOULDING	
	604911	MICROTEX FILTER & HANDLE ASSEMBLY	RSV-200M MACHINES
24	207998	FILTER & HANDLE ASSEMBLY	RSV-200 MACHINES
	220502	MAINS CABLE (2 WIRE/CSA PLUG)	
	220251	MAINS CABLE (2 WIRE/EURO PLUG)	
	220467	MAINS CABLE (2 WIRE/SOUTH AFRICAN PLUG)	
	220057	MAINS CABLE (2 WIRE/NO PLUG)	
	220192	MAINS CABLE (2 WIRE/SWISS PLUG)	
25	220249	MAINS CABLE (2 WIRE/UK PLUG)	
26	206353	HARNESS PIN	
27	321004	340MM LONG WHITE MOTOR LEAD ASSEMBLY	
36	218012	NVM1C/2 DISPOSABLE FILTER BAG	(NOT SHOWN)
28	219602	No6 X 1 INCH LONG POZI PAN PLASTITE SCREW	
29	219090	M4 X 8MM LONG POZI PAN SEMS SCREW	
30	219601	No8 X 3/8 INCH LONG POZI PAN PLASTITE SCREW	
31	321117	250MM LONG WHITE MOTOR LEAD	
32	227637	CABLE CLIP	
33	206462	RSV HARNESS ASSEMBLY	

EURO-MATIC PL Autoryzowany Dealer Numatic